

LA SERIES

Laser Collimated Beam Sensor

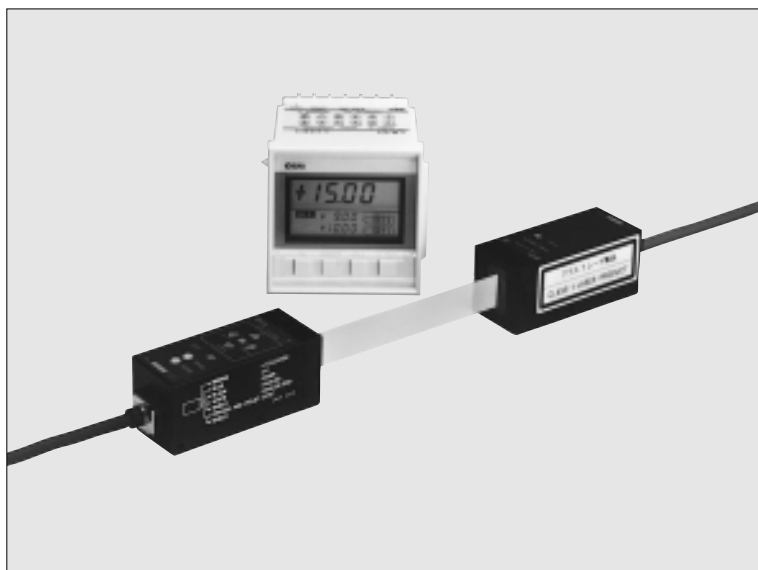

'Class 1' Laser Beam Sensor Safe for Your Eyes

CE Marked
Conforming to EMC Directive
(Excluding LA-C1)

Safe Laser Beam

This laser collimated beam sensor conforms to the Class 1 laser stipulated in IEC Publication 825 and JIS C 6802. Hence, safety measures such as protective gear are not necessary.

Precise Sensing in Wide Area

Sensing area: $15 \times 500\text{mm}$
Minimum sensing object: $\phi 0.1\text{mm}$
Repeatability: $10\mu\text{m}$ or less

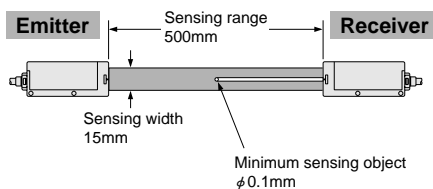

Easy Laser Beam Alignment

Four monitoring LEDs help you to easily align the emitter and the receiver.

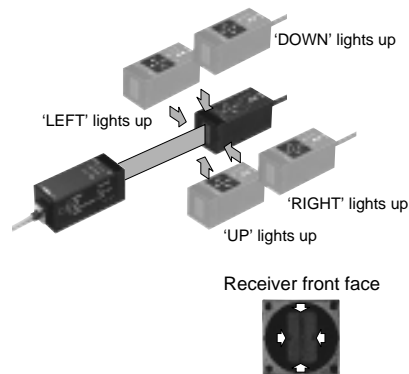

Versatile Mounting

The side view attachment (optional) enables versatile mounting styles.

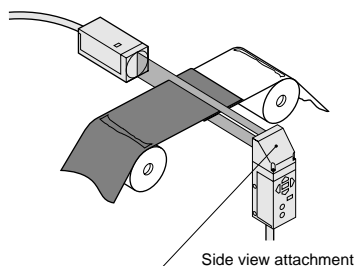

FDA Class 1 Type LA-511

LA-511 conforms to FDA Class 1. It is approved for use in U.S.A. by FDA.
(Refer to P.862 for FDA standards.)

The monitoring system checks whether the incident beam falls evenly on all the four receiving elements in the receiver window.

ORDER GUIDE

Laser collimated beam sensors

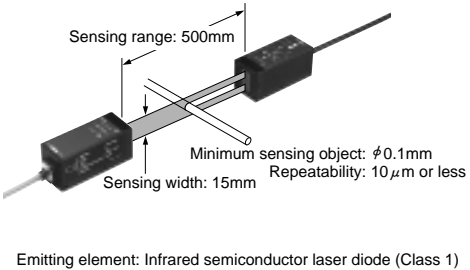
Type	Appearance	Model No.	Conforming standard
Class 1 type	 <p>Sensing range: 500mm Minimum sensing object: $\phi 0.1\text{mm}$ Sensing width: 15mm Repeatability: $10\mu\text{m}$ or less Emitting element: Infrared semiconductor laser diode (Class 1)</p>	LA-510	IEC and JIS standards
		LA-511	FDA standard

Laser sensor controller

Appearance	Model No.
 <p>DIN 72 × 72mm</p>	LA-C1

OPTIONS

Designation	Model No.	Description
Side view attachment	LA-SV1	Versatile mounting is possible as the laser beam can be bent at a right angle. <ul style="list-style-type: none"> • Sensing range: 500mm • Minimum sensing object: $\phi 0.1\text{mm}$ • Repeatability: $20\mu\text{m}$ or less (Note 1)
Digital panel controller (Note 2)	CA2-T2	NPN open-collector transistor This is a very small controller which allows two independent threshold level settings. <ul style="list-style-type: none"> • Supply voltage: 24V DC $\pm 10\%$ • No. of inputs: 1 No. (sensor input) • Input range: 1 to 5V DC • Main functions: Threshold level setting function, zero-adjust function, scale setting function, hysteresis setting function, start/hold function, auto-reference function, power supply ON-delay function, etc.
	CA-R2	Relay contact This is a multi-functional controller having mathematical functions, hold function, etc. <ul style="list-style-type: none"> • Supply voltage: 100 to 240V AC $\pm 10\%$ • No. of inputs: 2 Nos. (sensor input) • Input range: 1 to 5V DC • Power supply for sensor: 12V DC, 150mA • Main functions: Mathematical functions, process number selection function, hold function, scaling function, auto-reference function, power supply ON-delay function, measurement start delay function, hysteresis setting function, etc.
	CA-T2	NPN open-collector transistor
	CA-B2	NPN open-collector transistor With BCD output

Side view attachment

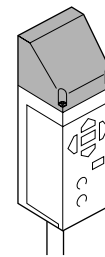

Two M3 (length 10mm) screws with washers are attached.

Digital panel controller

• CA2 series



• CA series



Notes :1) Mount **LA-SV1** on either the emitter or the receiver. If it is mounted on both sides, the monitor LEDs may not light off perfectly.

2) For further details, refer to P.776~ for the ultra-compact digital panel controller **CA2** series, and to P.766~ for the digital panel controller **CA** series.

SPECIFICATIONS

Laser sensor controller

Model No.		LA-C1
Item		
Supply voltage		12 to 24V DC \pm 10% Ripple P-P 10% or less
Current consumption		260mA or less
Power supply for sensor		12V DC, 70mA max.
Input	Sensor input	Input voltage range: 1 to 5V (Maximum allowable voltage: 10V DC) Input impedance: 1M Ω A/D conversion method: double integration method Sampling cycle: 50ms (20 times/sec.)
	Auto-reference input	Specifying timing of auto-reference function • Operation: Effective when NPN non-contact transistor input is Low • Signal condition: Low level 1.5V or less Low level output current 0.6mA or less Low level input time duration 0.5ms or more
Output	Comparative output	NPN open-collector transistor (3 outputs of HI, GO or LO) • Maximum sink current: 100mA • Applied voltage: 30V DC or less (between comparative output and 0V) • Residual voltage: 1V or less (at 100mA sink current) 0.4V or less (at 16mA sink current)
	Output operation	<div style="display: flex; justify-content: space-around;"> <div style="border: 1px solid black; padding: 5px;"> <p>Hysteresis mode</p> </div> <div style="border: 1px solid black; padding: 5px;"> <p>Window comparator mode</p> </div> </div>
	Response time	100ms or less (150ms or less while the auto-reference input is applied)
	Short-circuit protection	Incorporated
Display	Measurement value display	3 1/2 digit LCD display [Display cycle: 250ms (4 times/sec.)]
	Display range	- 19.99 to + 19.99
	Accuracy	\pm (0.15% \times Measurement value + 1 digit) at 23 \pm 1°C
	Setting value display	3 1/2 digit LCD display
Display range	- 19.99 to + 19.99	
Comparative output operation display	LCD display of 'HI', 'GO' and 'LO' (HI, GO or LO lights up when the respective output is ON)	
Environmental resistance	Ambient temperature	0 to + 50°C (No dew condensation), Storage: - 10 to + 60°C
	Ambient humidity	35 to 85% RH, Storage: 35 to 85% RH
	Noise immunity	Power line: 240Vp, 10ms cycle, and 0.5 μ s pulse width Radiation: 300Vp, 10ms cycle, and 0.5 μ s pulse width (with noise simulator)
	Vibration resistance	10 to 55Hz frequency, 1mm amplitude in X, Y and Z directions for two hours each
	Shock resistance	300m/s ² acceleration (30G approx.) in X, Y and Z directions for three times each
Connection method	Screw-on terminal block	
Material	Enclosure: Polycarbonate, Front bezel: ABS, Terminal block: PBT, Front panel: Acrylic, Protector: Acrylic	
Weight	230g approx.	

SENSING CHARACTERISTICS (TYPICAL)

Correlation between setting distance and excess gain

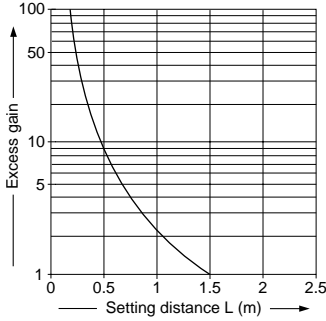

Correlation between transverse deviation and output voltage

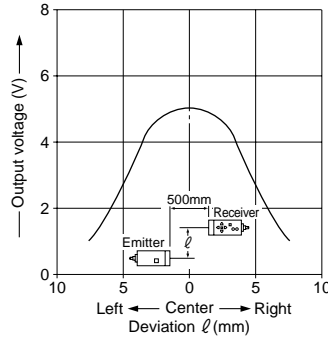

Correlation between interrupted beam width and output voltage

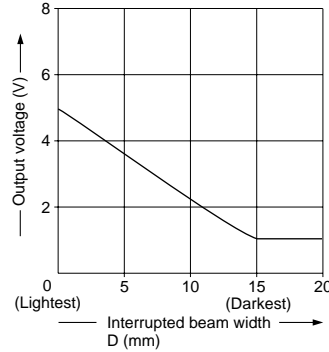

Correlation between ambient temperature and output voltage variation rate

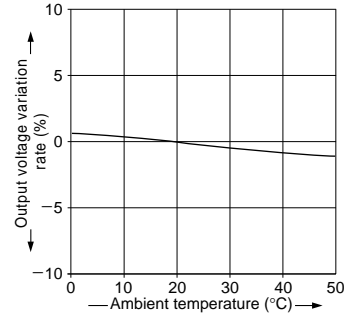

PRECAUTIONS FOR PROPER USE

Laser collimated beam sensor



This product is not a safety sensor. Its use is not intended or designed to protect life and prevent body injury or property damage from dangerous parts of machinery. It is a normal object detection sensor.



Safety measures for laser beam products

- The safety standard IEC Publication 825 specifies the application of laser beam products. Please read it carefully before using the laser beam sensor.
- Do not expose your eyes to the laser beam through optical instruments, like a lens.

Safety standards for laser beam products

- A laser beam can harm human being's eyes, skin, etc., because of its high energy density. IEC and JIS have classified laser products according to the degree of hazard and the stipulated safety requirements.

LA-510 and LA-511 are identified as a 'Class 1' laser products.

Class	Applicable model No.	Degree of danger
Class 1	LA-510 LA-511	Intrinsically safe design.
Class 2	—	Visible and low power (wavelength 400 to 700nm). Eyes react instinctively to laser beam and protect themselves.
Class 3A	—	Dangerous if eyes are exposed to laser beam through optical means. Visible beam should be 5mW or less. Invisible beam should not exceed 5 times the Class 1 power.
Class 3B	—	Dangerous if eyes are exposed to laser beam directly. Unfocused, pulsed laser radiation 0.5W or less can be observed by means of diffuse reflection.
Class 4	—	Too intense. Even diffuse reflection is possibly dangerous. It can burn the skin or cause a fire.

Mounting

- The emitter and the receiver must face each other with proper slit orientation so that the beam can be received.

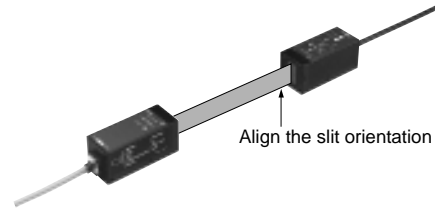

- The tightening torque should be 1.17N·m or less. When mounting the sensor with the attached sensor mounting bracket, the sensor must be fixed on both sides.

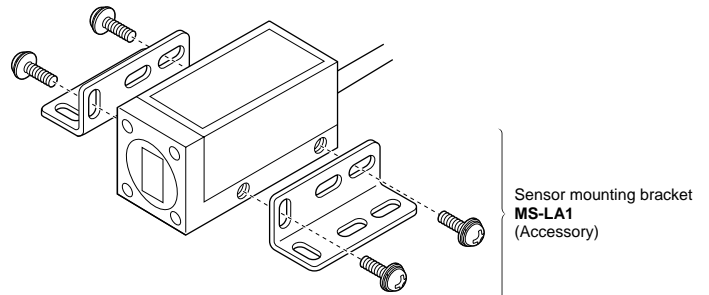

PRECAUTIONS FOR PROPER USE

Laser sensor controller

Threshold level setting

• Operation panel description

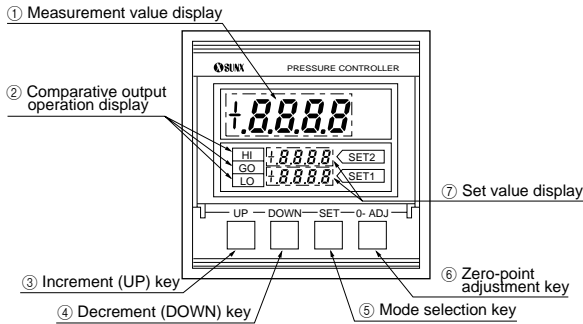

• Output mode

Two output modes are possible depending on the relative magnitudes of **SET 1** and **SET 2**.

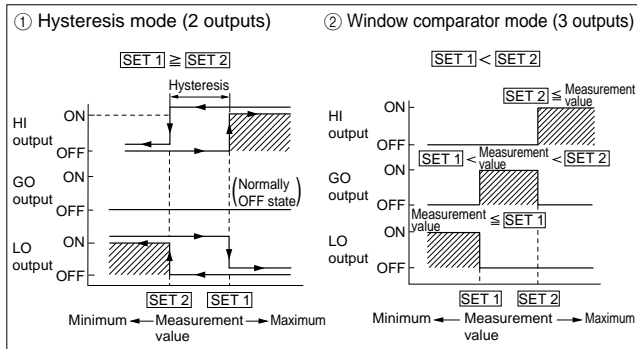

Note: In the window comparator mode, **SET 1** and **SET 2** should be separated by 2 digits or more.

• Setting method

SET 1, **SET 2** setting modes and **Sensing mode** can be cyclically selected by pressing the **SET** key.

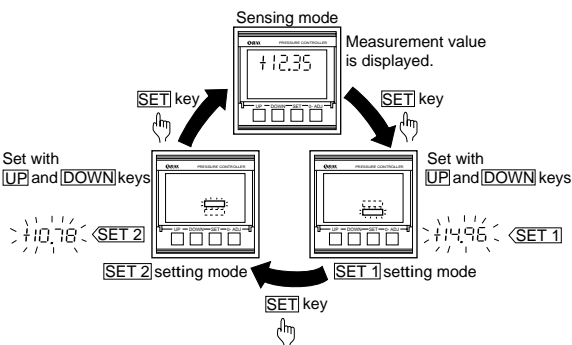

• Setting procedure

<Light width indication (indicated with '+')>

Step	Setting item	Display mode	Setting procedure
1	Zero-point adjustment	Sensing mode	Press the [0-ADJ] key under the Darkest condition (entire beam interrupted).
2	Full-scale adjustment	Sensing mode	Enter the sensor into the Lightest condition (entire beam is received). Turn the span adjuster until the displayed value becomes "+ 15.00".
3	SET 1 level setting	SET 1 setting mode	Use [UP] and [DOWN] keys to set the level of SET 1 . To increase the value, press the [UP] key. To decrease the value, press the [DOWN] key. + 19.99 + 19.98 ↑ [UP] + 0.00 ↓ [DOWN] - 19.98 - 19.99
4	SET 2 level setting	SET 2 setting mode	Set the level of SET 2 with [UP] and [DOWN] keys.
5	—	Sensing mode	Press the [SET] key to complete the setting procedure.

<Interrupted beam width indication (indicated with '-')>

After completing Step 2 'Full-scale adjustment' given above, press the **[0-ADJ]** key again.

The subsequent procedure is similar to that for 'Light width indication'.

Note: The output and operation display remain unchanged while **SET 1** or **SET 2** is adjusted.

★ If an error occurs, take the following corrective action.

Error code (Note 1)	Cause	Corrective action
Err 1	Short-circuit causing excess current flow.	Turn the power off and check the load.
Err 5	Set value exceeds the possible setting range (± 19.99) during the auto-reference input.	Check the set value.
- - - - (Note 2)	<ul style="list-style-type: none"> Input voltage exceeds 5.25V. The measurement value exceeds the display range ($- 19.99$ to $+ 19.99$). 	<ul style="list-style-type: none"> The input voltage should not exceed 5.25V. Keep the measurement value within the display range.

Notes: 1) The error code blinks in the measurement value display.

2) '- - - -' does not blink.

3) Please contact our office if 'Err 2' is displayed.

DIMENSIONS (Unit: mm)

**LA-510
LA-511**

Laser collimated beam sensor

Emitter

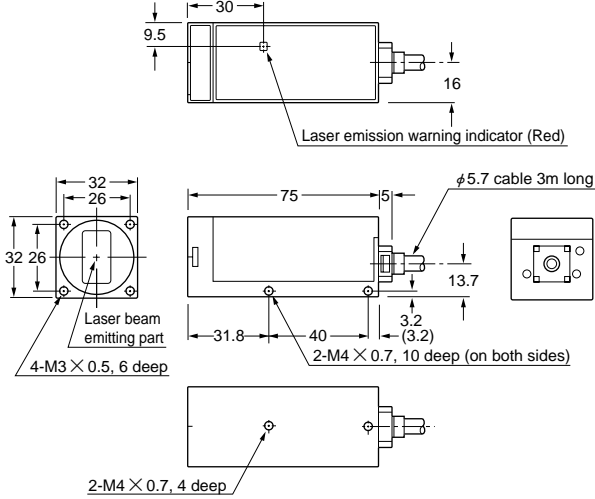

Receiver

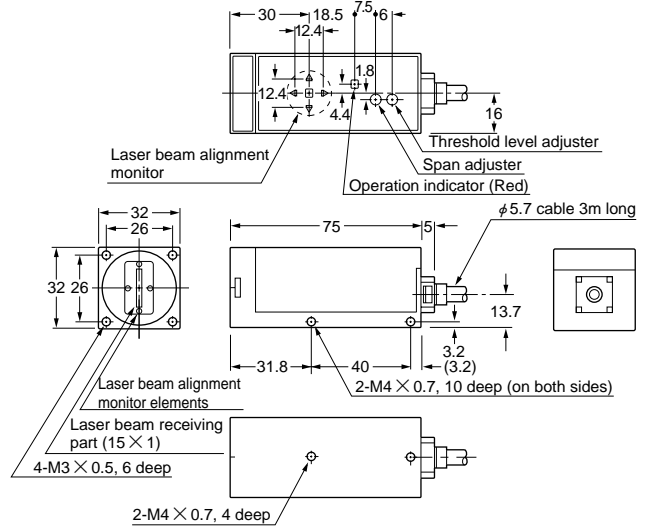

MS-LA1

Sensor mounting bracket (Accessory for LA-510 and LA-511)

Assembly dimensions

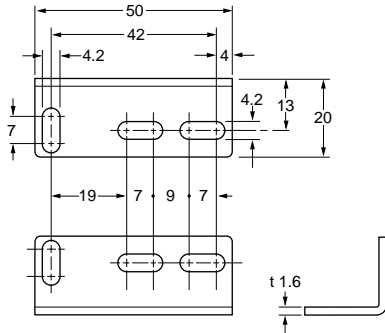

Material: Cold rolled carbon steel (SPCC)
(Uni-chrome plated)

Set of two L-shaped brackets and four
M4 (length 8mm) screws with washers

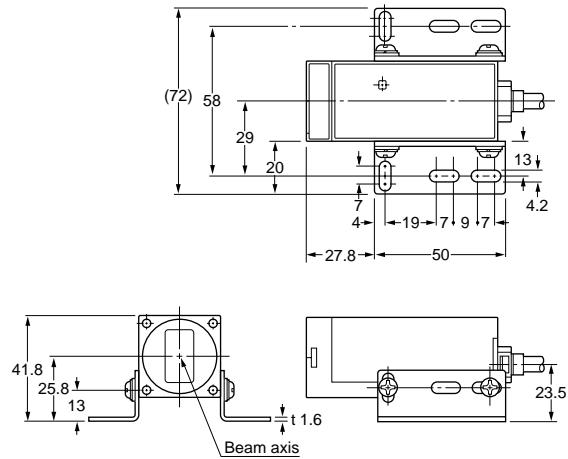

LA-SV1

Side view attachment (Optional)

Assembly dimensions

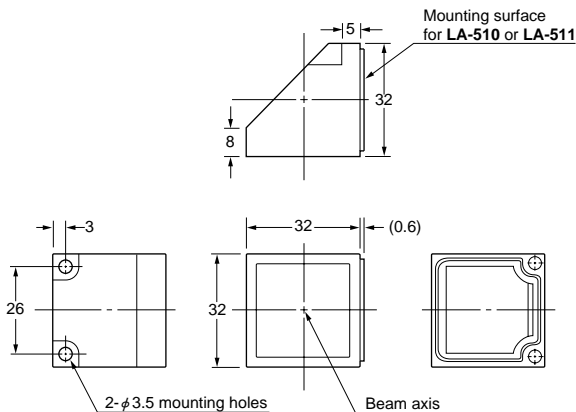

Material: Glass (Front protection cover, Aluminum evaporated mirror)
Polyetherimide (Enclosure)

Two M3 (length 10mm) screws with washers are attached.

